



Precision dispensing nozzles

**POLY DISPENSING SYSTEMS**  
S Y S T E M E S D E D O S A G E I N D U S T R I E L

122, Chemin de la Cavée - 78630 Orgeval • [contact@polydispensing.com](mailto:contact@polydispensing.com) • Tél : 01.39.62.40.92  
[www.polydispensing.com](http://www.polydispensing.com)

## High precision thin wall nozzles

### Features

- Thin wall perpendicular to exit aperture - minimum facial area
- Monolithic construction
- Unitized Hub & Core
- Non-Compliant Fluid Path
- Color Coded
- Luer Compatible
- Smooth Contiguous Flow Path
- Low Restriction
- Low Pressure
- High Flow Rates
- Minimized volume ahead of luer taper
- Low Resistance

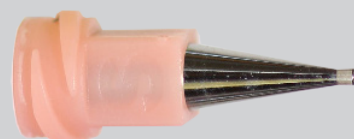
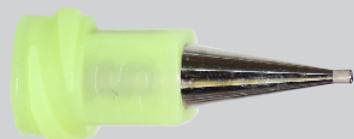
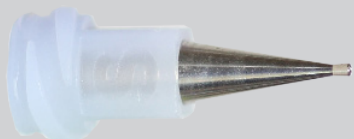

Precision Dispensing Nozzles offer a cost effective alternative technology to facilitate fluid delivery to the work piece in the form of microdots, tiny lines and accurate patterns. New capability can be gained from existing dispensing equipment to enable process possibilities previously not feasible. The huge cost savings over precision machined nozzles of this geometry make many applications practical for volume manufacturing while reducing variation by enhancing placement precision, deposit accuracy and repeatability.

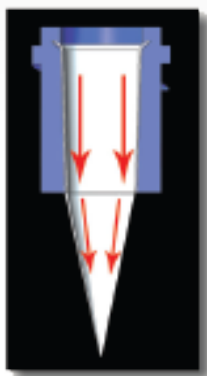

Traditional dispensing nozzles have restricted flow paths that increase back pressure and decrease flow rates resulting in low throughput, constant clogging, and shortened life span of motors, pumps, and seals.

Our precision dispensing nozzles offer superior, clog-resistant performance, with reduced back pressure at increased flow rates.

The combination of a thin wall coupled with a monolithic design is a metallurgical marvel made possible due to proper material selection. The copper alloys used to construct the nozzle exhibit an innate propensity to work harden at a rate that is substantially less than stainless steel. More progressions can be used to produce finer detail with a thinner wall that is generally more rigid and able to handle higher pressures without compliance. The exit aperture for a given gage size is much larger in comparison to cannulae based on medical gauge tubing apertures due to the extremely thin wall. A smooth surface finish decreases the thickness of the boundary layer at the fluid-wall interface further alleviating obstruction and reducing the propensity to clog with filled fluids. The nozzles also completely block exposure to ambient UV light that can cause problems with curing of UV adhesives in the nozzle.

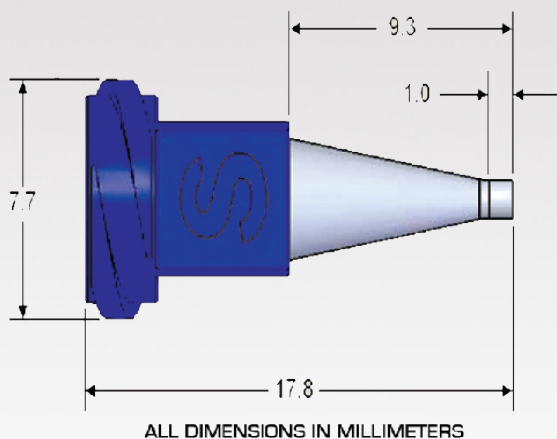

Sample Precision Nozzle P/N:  
A-100-00-00-XX (XX = Gage)



## Micro Dispensing Nozzles

Sample Micro Nozzle P/N:  
A-100-00-00-XX (XX = Part#)

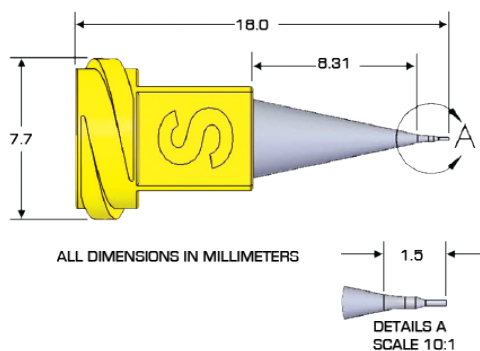

## Precision Nozzle Selection Guide

Color Code	Gage	ID Inches (mm)	OD Inches (mm)	FLOW RATE PERFORMANCE Thin Wall nozzle VS. Medical needles		
				Thin wall nozzle	Effective Flow Rate Improvement	Medical needle
Pink	18	1,039 mm (0,040")	1,240 mm (0,048")	18g	>25%	15g
				18g	>150%	16g
				18g	>300%	18g
Orange	19	0,861 mm (0,033")	1,059 mm (0,041")	19g	>25%	16g
				19g	>150%	18g
				19g	>300%	19g
Green	20	0,681 mm (0,026")	0,881 mm (0,034")	20g	>25%	18g
				20g	>150%	19g
				20g	>300%	20g
Blue	21	0,610 mm (0,024")	0,810 mm (0,031")	21g	=	18g
				21g	>150%	20g
				21g	>300%	21g
Purple	23	0,564 mm (0,022")	0,635 mm (0,025")	23g	=	18g
				23g	>250%	21g
				23g	>1000%	23g
Light Orange	25	0,437 mm (0,017")	0,508 mm (0,020")	25g	>100%	22g
				25g	>600%	23g
				25g	>1000%	24g
Red	27	0,335 mm (0,013")	0,406 mm (0,016")	27g	=	21g
				27g	>200%	23g
				27g	>600%	25g
				27g	>1000%	27g
Black	30	0,234 mm (0,009")	0,305 mm (0,012")	30g	>25%	23g
				30g	>150%	25g
				30g	>400%	27g
Dark Blue	31	0,152 mm (0,006")	0,254 mm (0,010")	30g	>1000%	30g
				30g	>1000%	30g
				30g	>1000%	30g
Orange	32	0,101 mm (0,004")	0,203 mm (0,008")	30g	>1000%	30g
				30g	>1000%	30g
				30g	>1000%	30g
Yellow	33	0,051 mm (0,002")	0,152 mm (0,006")	30g	>1000%	30g
				30g	>1000%	30g
				30g	>1000%	30g

## Poly Dispensing Systems

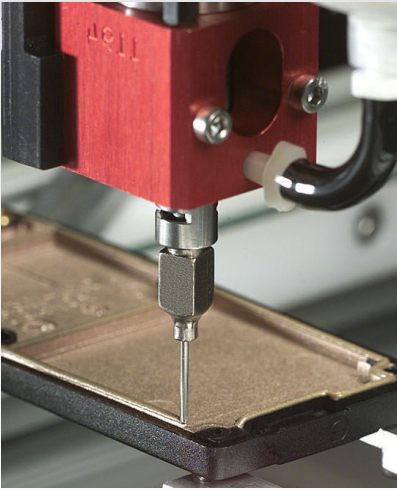

### FRANCE - NORTH AFRICA

Poly Dispensing Systems  
122, Chemin de la Cavée  
78630 Orgeval

#### FRANCE

☎ + 33 (0)1 39 62 40 92

📠 + 33 (0)1 39 62 40 94

[www.polydispensing.com](http://www.polydispensing.com)

### SWITZERLAND

John P. Kummer AG  
Riedstr. 1  
6330 Cham

Suisse

☎ +41 41 748 10 80

📠 +41 41 748 10 89

[www.jpnummer.com](http://www.jpnummer.com)

### BELGIUM- NETHERLANDS

### LUXEMBOURG

Gentec Benelux  
Rue de L'Industrie,  
12 B-1400 Nivelles

BELGIQUE

☎ +32 2 351 1800

📠 +32 2 351 1962

[www.gentec-benelux.com](http://www.gentec-benelux.com)

PDS SAS is a french company that commercializes a wide range of dosage equipments, proven and effective.

Distributed in over 20 countries around the world these equipments provide tailored solutions to many users in order to improve technically their manufacturing and reduce their productions costs.

Our collaborators and sales engineers all have a strong technical competences. They are able to answer your questions and offers you, after analysis, the right solution for your particular needs.

- NON CONTRACTUAL DOCUMENT -

# POLY DISPENSING SYSTEMS

S Y S T E M E S   D E   D O S A G E   I N D U S T R I E L

122, Chemin de la Cavée - 78630 Orgeval • [contact@polydispensing.com](mailto:contact@polydispensing.com) • Tél : 01.39.62.40.92

[www.polydispensing.com](http://www.polydispensing.com)